

KUKA

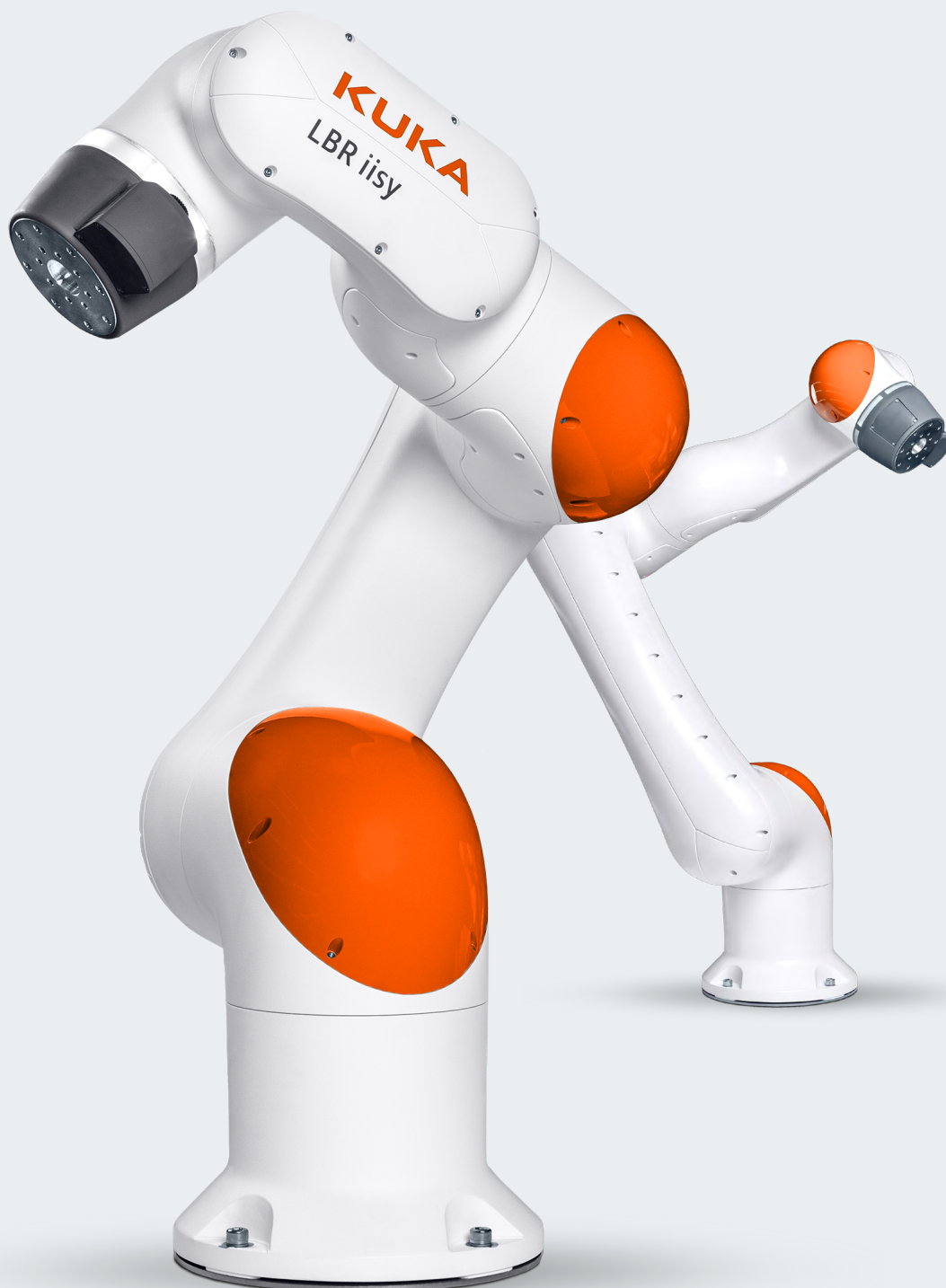

LBR iisy

Quick Setup Guide



01 Unbox all components except the robot

Leaving the LBR iisy robotic arm in the box, remove all other components, accessories and cables.



1.1 Take off the lid

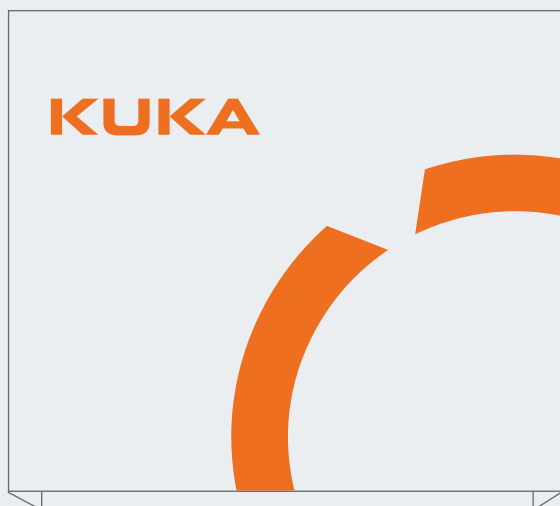

1.2 Remove the sides of the box (two parts) and the cover layer

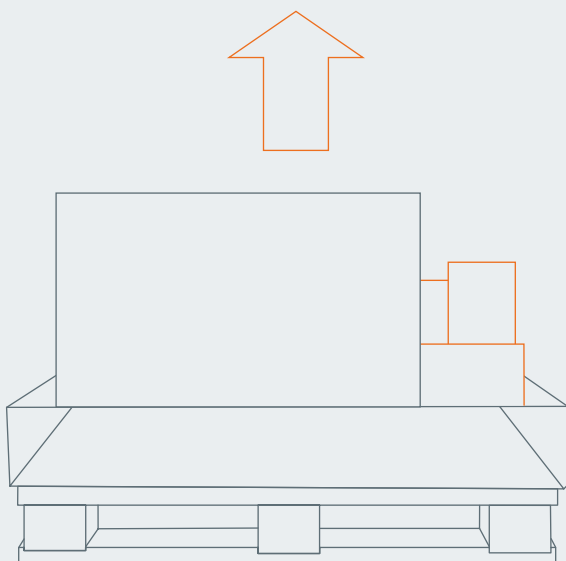

1.3 Leave the LBR iisy robot in the box. Take out everything else.

02 Check contents of the box

The letters on this pages correspond to the letters in a later step when connecting cables to the controller and power supply.

Important note. Depending on your configuration, the box may include additional accessories, components or cables that are not listed here.

a KUKA smartPAD pro and cable

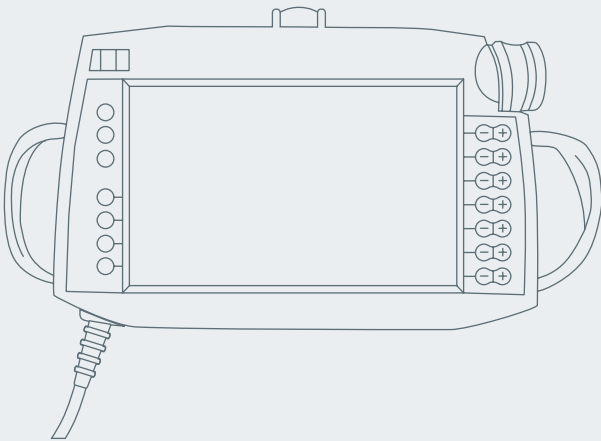

c KR C5 micro robot controller

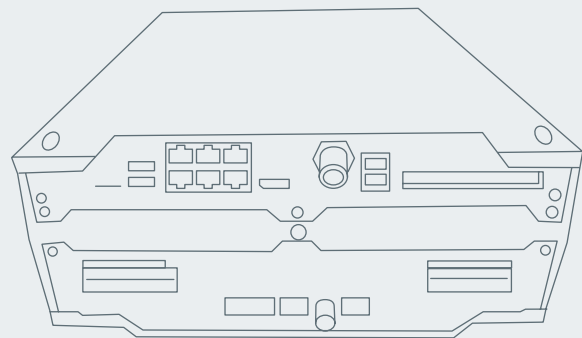

b Connection cable set (engine cable & data cable)

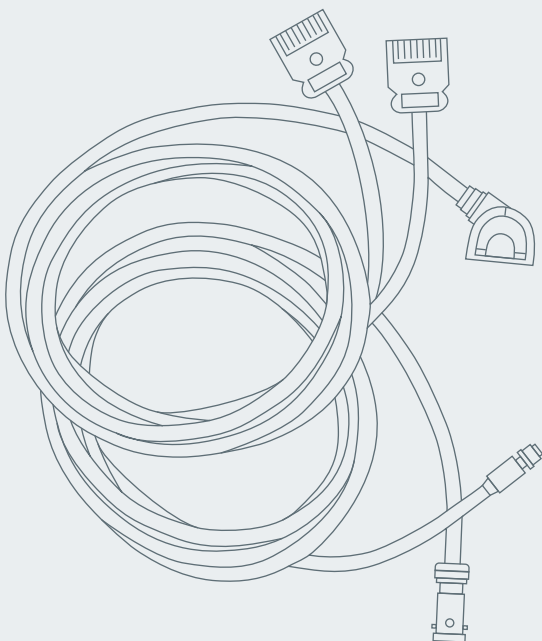

d KR C5 micro power cable

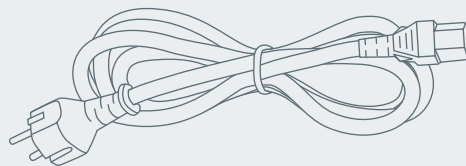

e Grounding wire

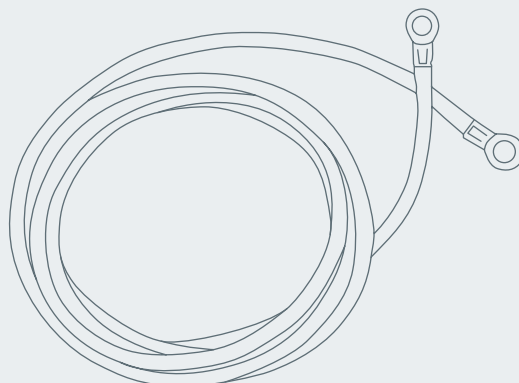

03 Transport and mount LBR iisy

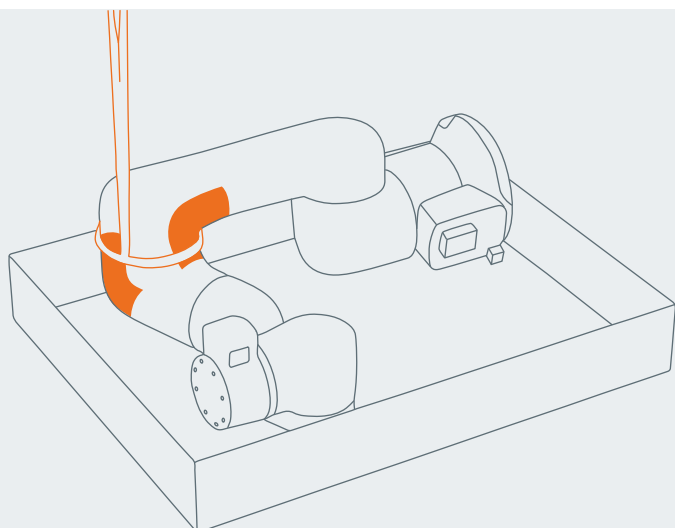

3.1 Prepare for transport

Tighten a sling around axis 3 (A3) of the LBR iisy robotic arm. Lift the robot from the holder into the upright position.

Alternative: To move the robot by hand, grab the LBR iisy by the highlighted positions.

⚠ Two people are required for this option.

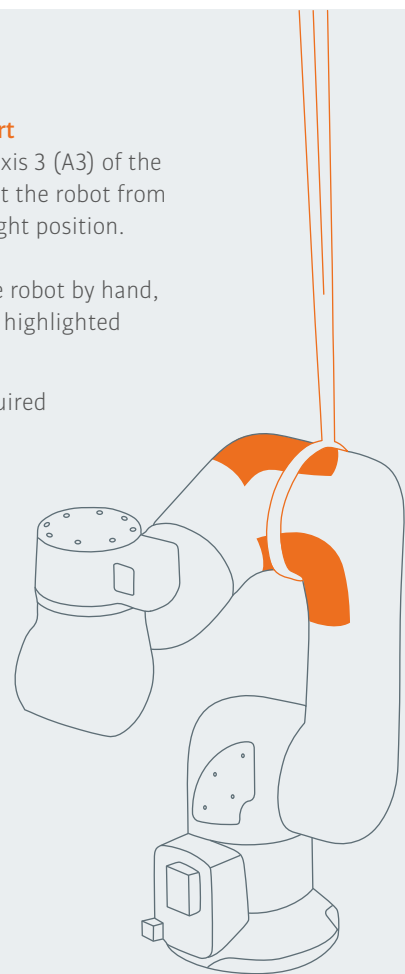

3.2 Lift up slowly

Use a hoist to lift up the robot from the horizontal position and remove the packaging material.

3.3 Hoist transport

Use a hoist to transport the LBR iisy to its final installation location.

⚠ Keep the robot inside the sling until it is mounted completely.

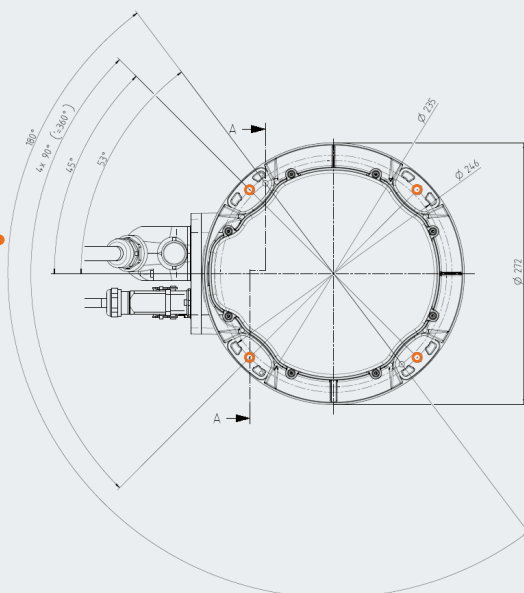
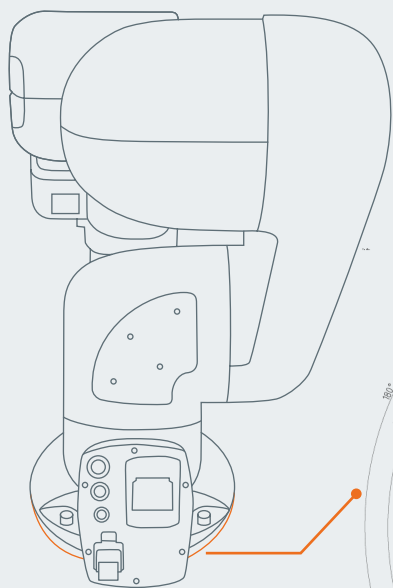

4.1 Mounting

Follow the safety instructions and mounting patterns included in the LBR iisy documentation. To access this documentation, log in to KUKA Xpert by scanning the QR code below. The mounting pattern is also shown here to the left.

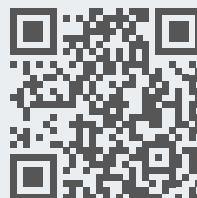

04 Connect all cables

There are three wires that need to be connected between the LBR iisy and the KR C5 micro controller.

Additionally, the smartPAD Pro and the power cable have to be connected to the KR C5 controller.

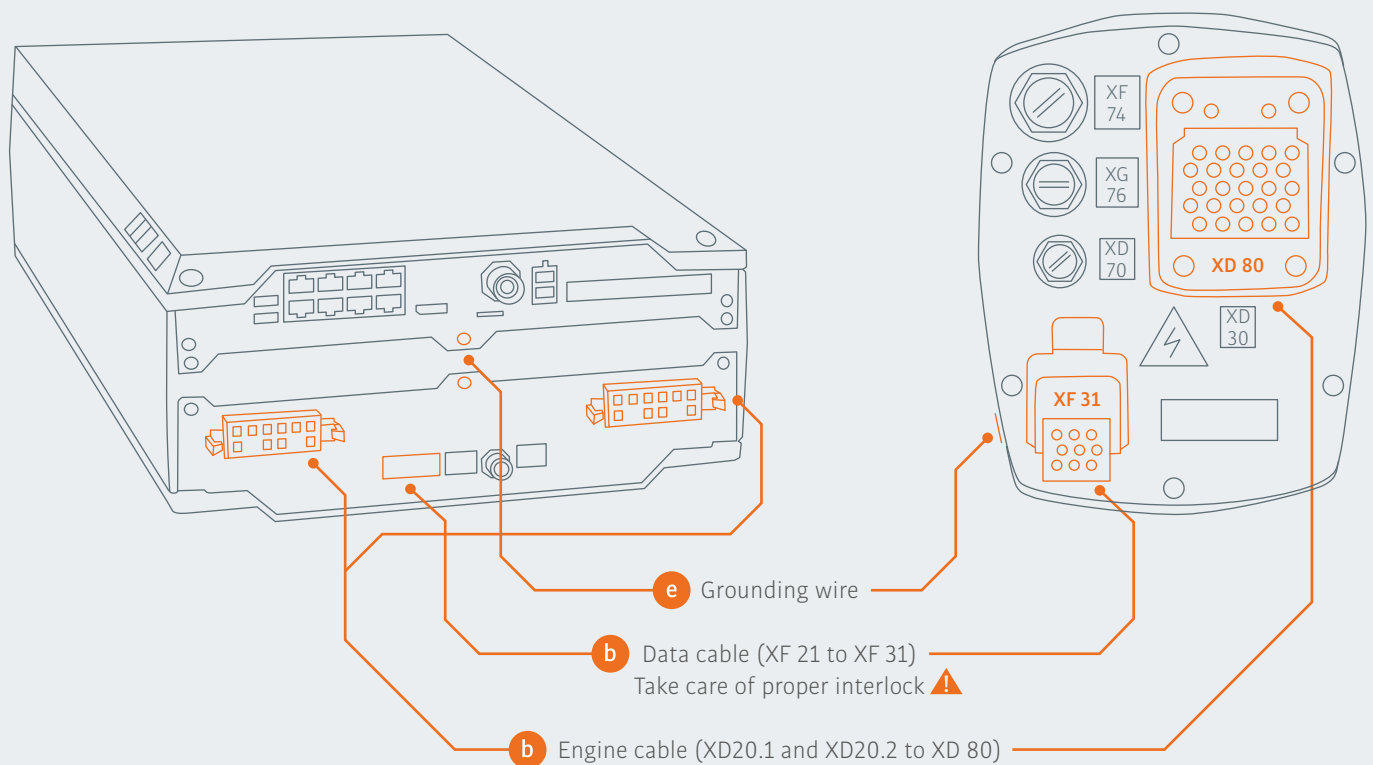

Frontside

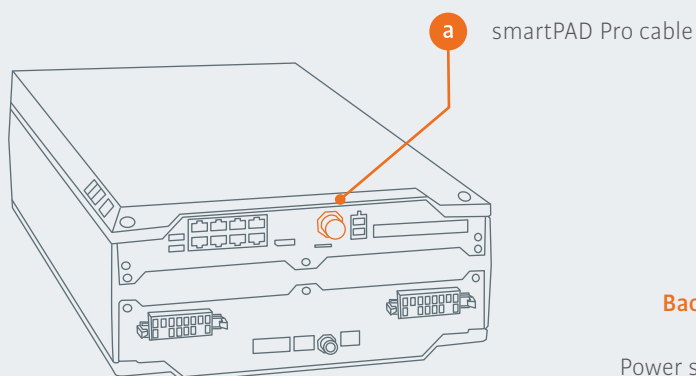

Backside

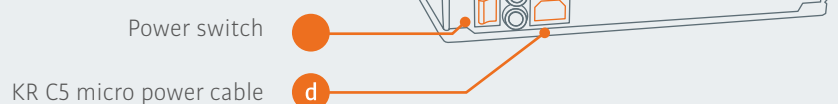

05 Mount the end of arm tooling

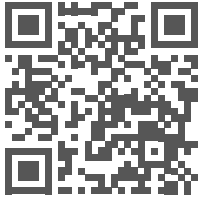

Please mount your tool to the flange of the LBR iisy according to individual specifications. Depending on the tool used, you can download a toolbox from the iiQKA ecosystem or configure your tool manually inside the iiQKA user interface.

For more details about this process, please scan the QR code.

06 Done!

Ensure all cables are connected properly before pressing the power button on the KR C5 micro controller.

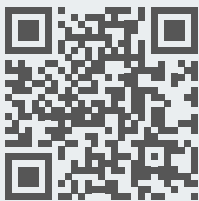
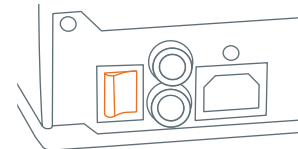

Safety Notice. The robot is equipped with a basic safety configuration which is out of the box functional. Additional functions, e.g. collision detection or reaction in free space or clamping situations need to be configured.

In order to operate the system safely, setup your safety configuration in a way that ensures the safety of people and property. If you do not know how to ensure the safe operation of the robot please contact KUKA for help.

07 Additional iiQKA Resources



iiQKA User Forum



iiQKA Help Portal on KUKA Xpert*

*requires registration with an account on my.kuka



iiQKA Ecosystem Marketplace

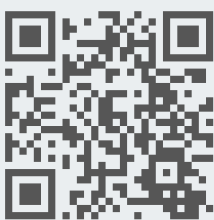

- kuka.com/contacts
- facebook.com/kukaglobal
- youtube.com/kukarobotgroup
- twitter.com/kukaglobal
- linkedin.com/company/kukaglobal

Details provided about the properties and usability of the products are purely for information purposes and do not constitute a guarantee of these characteristics. The extent of goods delivered is determined by the subject matter of the specific contract. No liability accepted for errors or omissions. Subject to alterations. © 2022 KUKA